

## Light Duty Scissor Lift Specification

Model	C Raised Height	B Closed Height	E x A Platform W x L	E x D O/A W x L	F Handle Height	Wheel Dia	Approx Weight (KG)	Reference
STEEL	780	255	450 x 760	450 x 990	940	125	41	SC-150-S-M
ALUMINIUM	780	255	450 x 760	450 x 990	940	125	24	SC-150-S-M-ALU-PC

All dimensions are in mm unless otherwise shown

### Options

- Second Braked wheel
- Stainless Steel top cover
- Plastic roller conveyor top (Increases closed/raised height by 60mm)
- Ball top
- Bellows safety skirt
- Rubber Mat

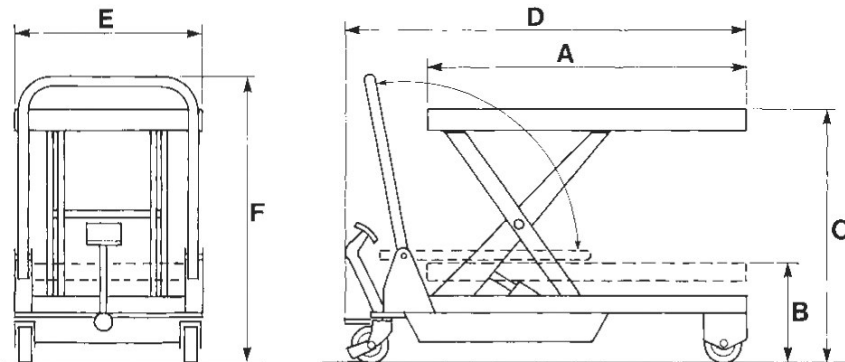

This document was downloaded from – [www.manualhandlingsolutions.com](http://www.manualhandlingsolutions.com)